

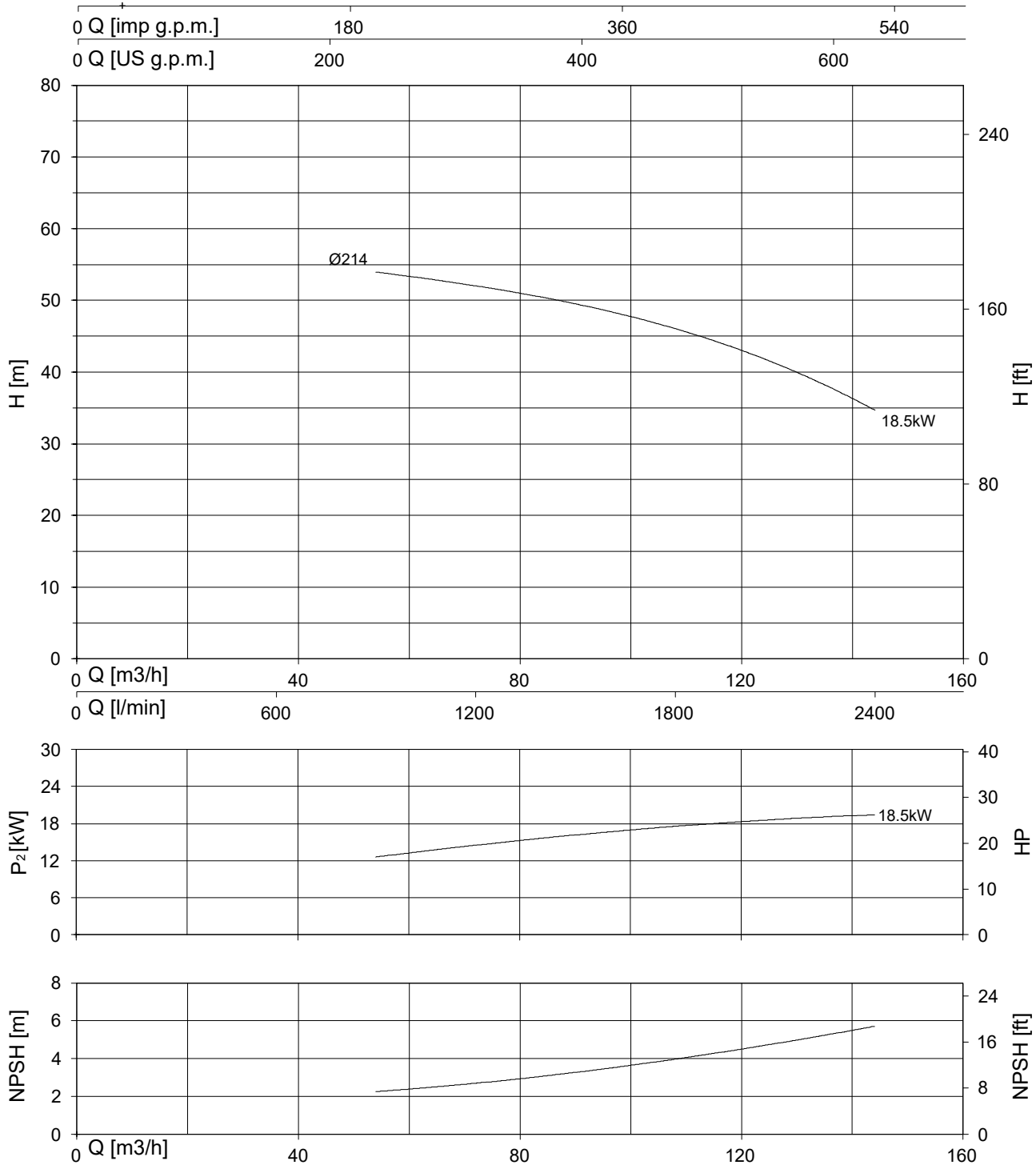

~ 2900 r.p.m HL - HLR
65 - 200



CENTRIFUGHE / CENTRIFUGAL / CENTRIFUGAS / CENTRIFUGES

TYPE	Nominal Power (kW)	Motor Size	Q (m ³ /h - l/min)										
			0	54	60	66	72	78	84	96	108	120	132
			0	900	1000	1100	1200	1300	1400	1600	1800	2000	2200
H (m) / pump input power (kW)													
HL(R)65-200/18.5	18.5	160L	55.5	55	53.4	52.7	52.0	51.3	50.4	48.6	45.9	37.1	34.0

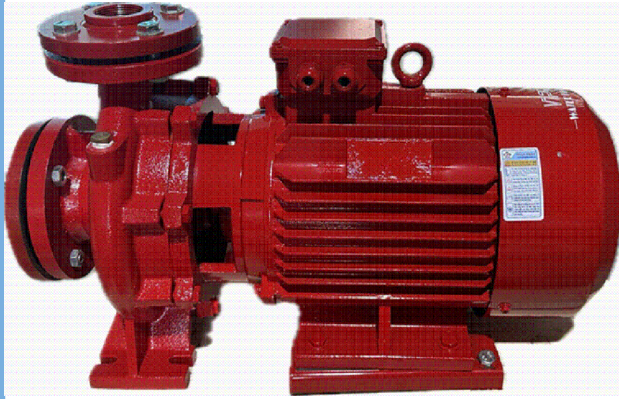

APPLICATION

- Building
- Drainage, irrigation, sprinkling, water supplies
- General industry (plastics, paint, textiles, paper)
- Heating systems, air-conditioning, cooling tower
- Swimming pool, washing systems...
- * Standard supply with counter-flange

ỨNG DỤNG

- Xây dựng, nhà cao tầng
- Thoát nước, thủy lợi, tưới tiêu, cung cấp nước
- Hệ thống chữa cháy
- Công nghiệp (Hệ thống giải nhiệt, bột giấy, thực phẩm, hóa chất, dệt nhuộm...)
- Hệ thống sưởi, điều hòa không khí, tháp giải nhiệt
- Hồ bơi, hệ thống rửa ...
- * Máy được cung cấp kèm theo mặt bích.

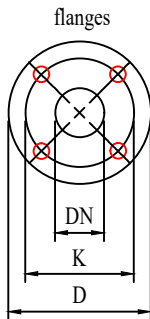

DN	D	K	holes	
			n°	Ø
32	140	100	4	18
40	150	110	4	18
50	165	125	4	18
65	180	145	4	18
80	200	160	8	18
100	220	180	8	18
125	250	210	8	18

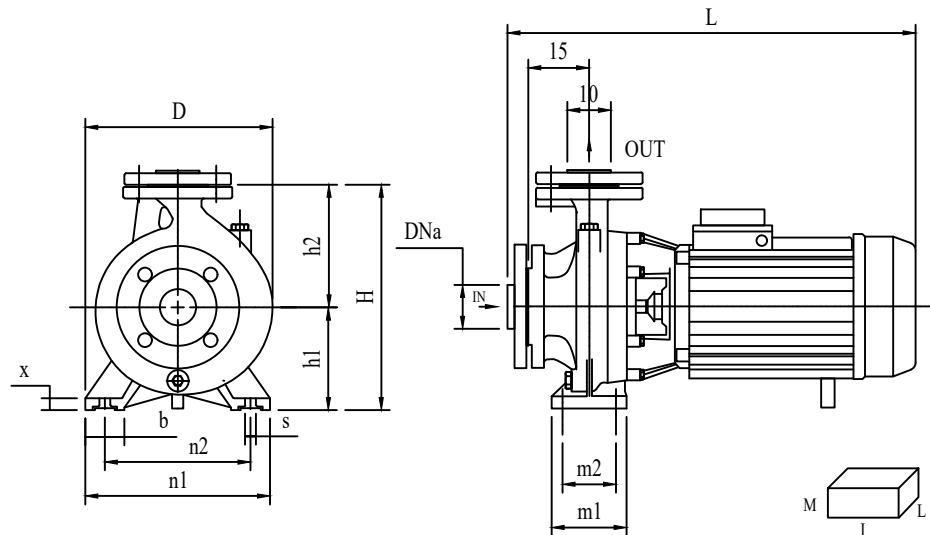

DNA	DNM	DIMENSIONS (mm)																Kg
		a	h1	h2	m1	m2	n1	n2	b	x	s	L	D	H	I	K	M	
80	65	100	180	225	125	95	320	250	65	14	14	750	320	430	810	354	480	164.5

Notes